

PROFILE PËR TERASA & BALLKONA

PROFILET E XHAMAVE TË BALLKONIT - PROFILE PËR DYER
& DRITARE - PROFILET SISTEM - PROFILET E FASADËS
STRUKTURALE & GJYSËM STRUKTURALE - PROFILE C60

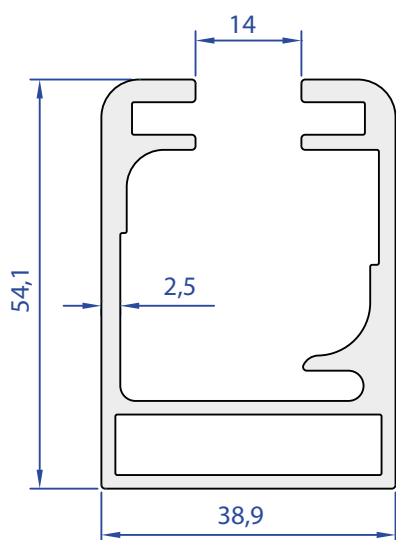

75116-00
1,445 Kg/m

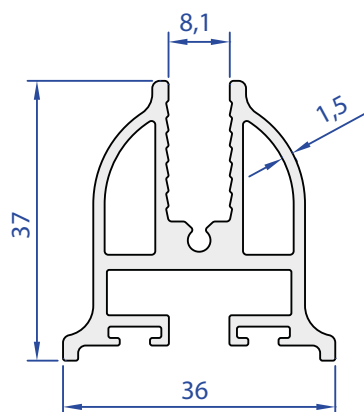

75154-00
0,855 Kg/m

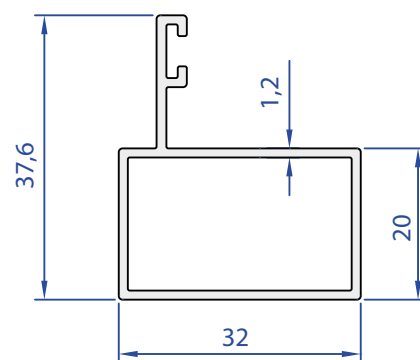

75121-00
0,411 Kg/m

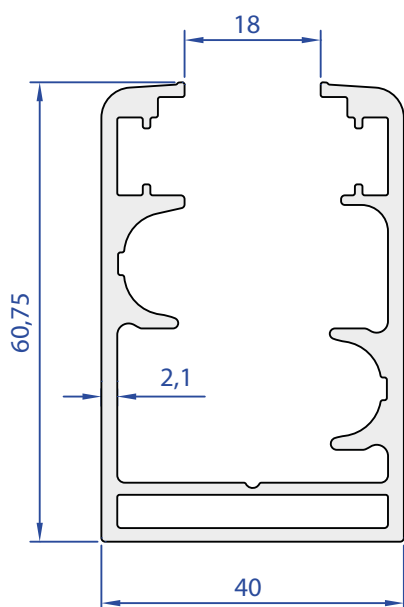

75535-00
1,458 Kg/m

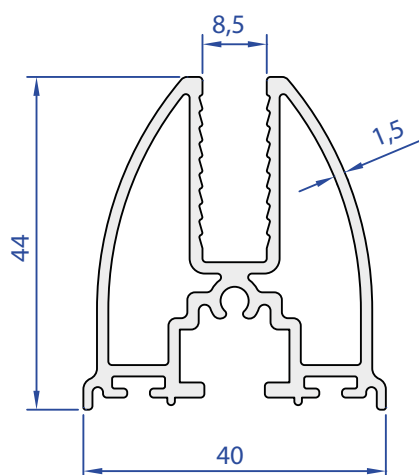

75536-00
0,983 Kg/m

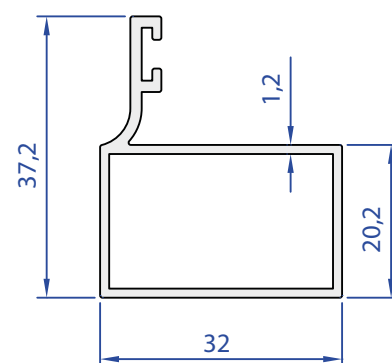

75537-00
0,428 Kg/m

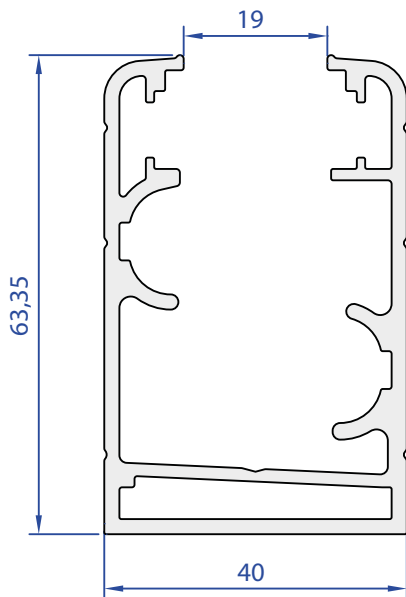

75472-00
1,439 Kg/m

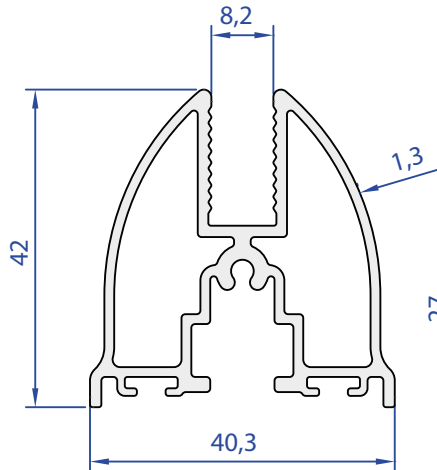

75469-00
0,876 Kg/m

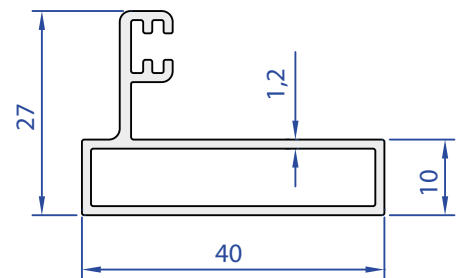

75324-00
0,435 Kg/m

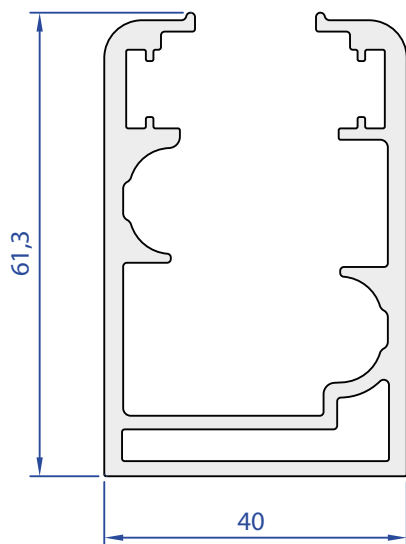

75397-00
1,532 Kg/m

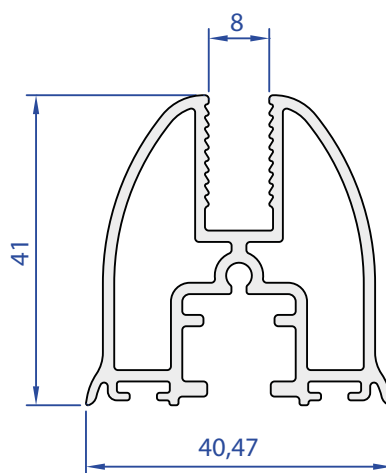

75398-00
0,938 Kg/m

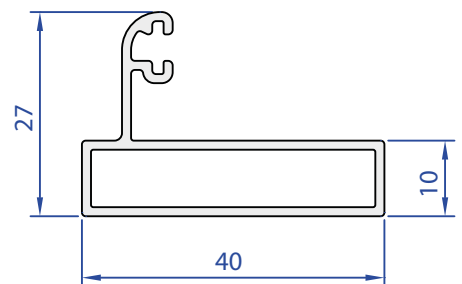

75400-00
0,413 Kg/m

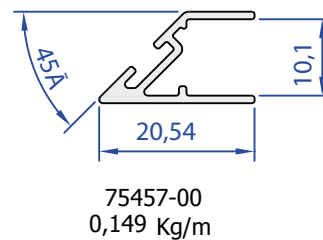
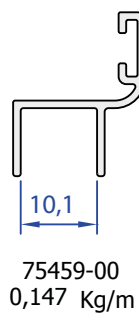
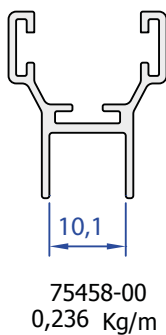
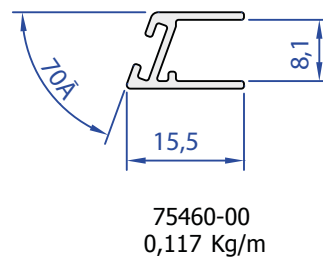
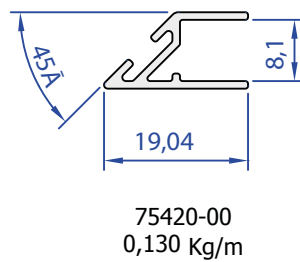
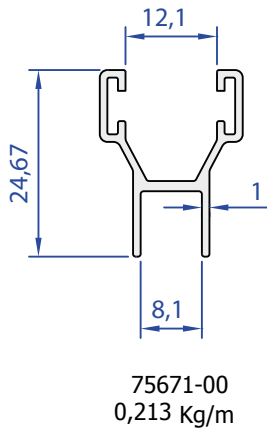
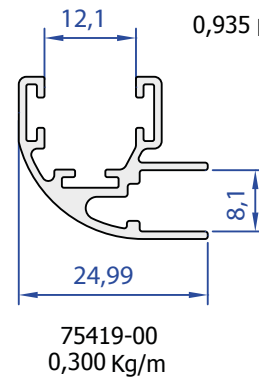
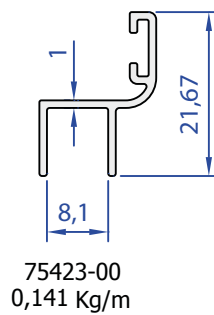
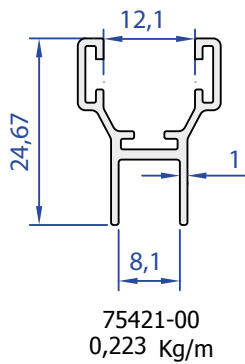
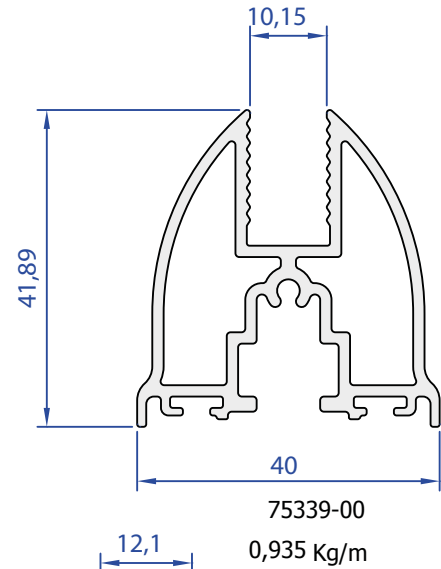
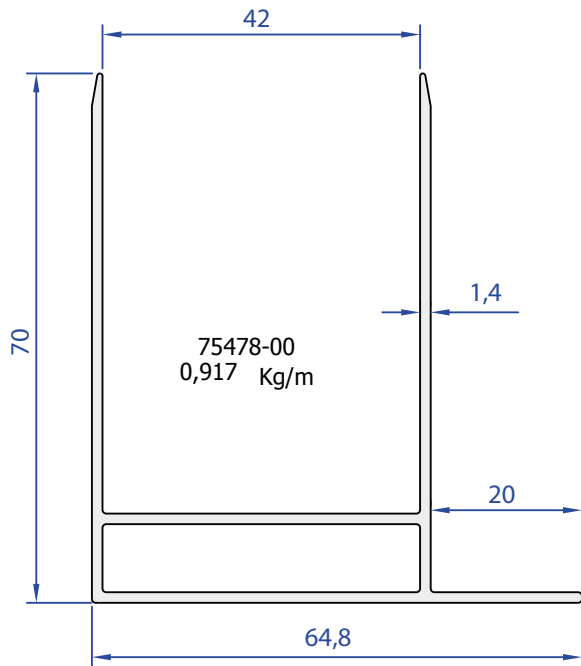

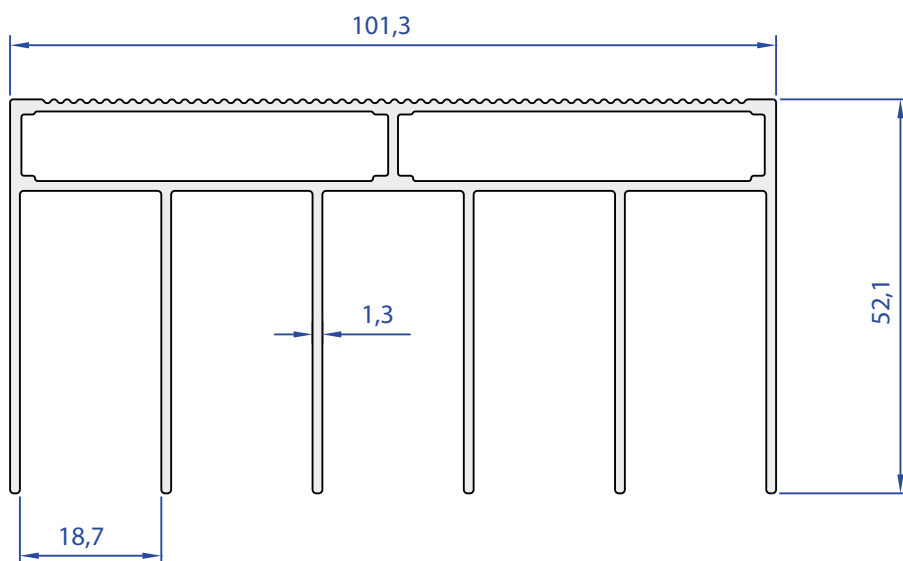

75353-00
1,708 Kg/m

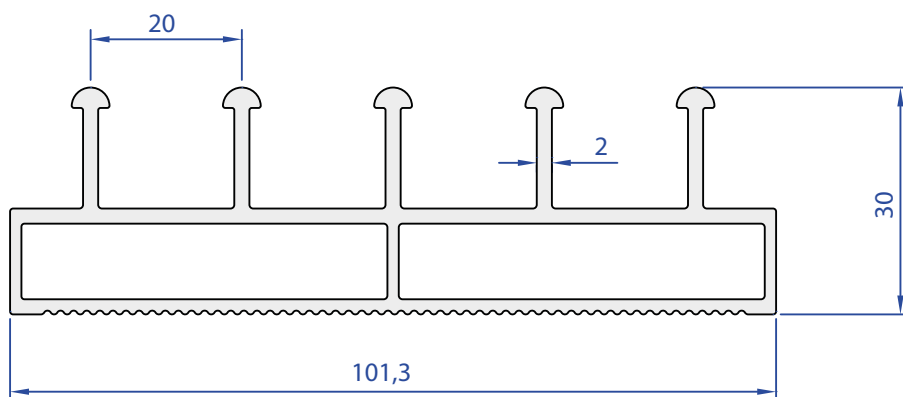

75352-00
1,643 Kg/m

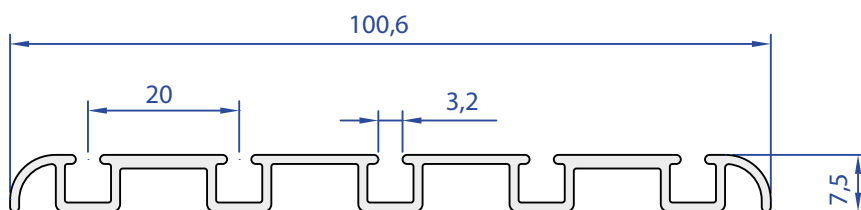

75425-00
0,634 Kg/m

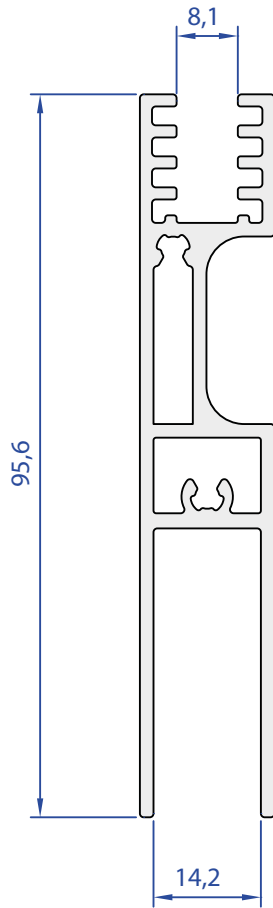

75422-00
1,310 Kg/m

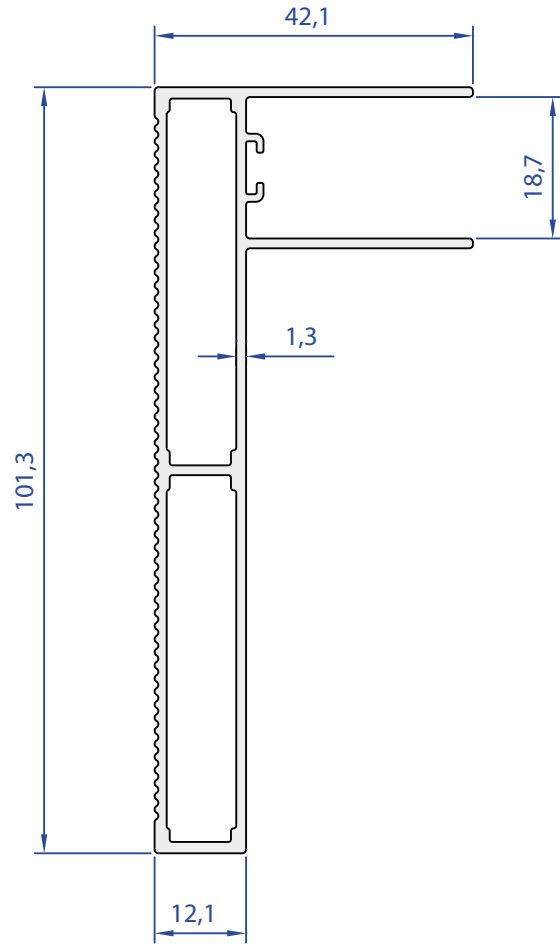

75354-00
1,093 Kg/m

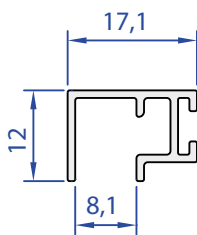

75424-00
0,142 Kg/m

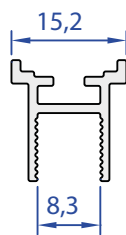

75382-00
0,155 Kg/m

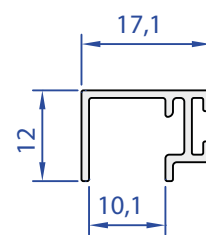

75483-00
0,136 Kg/m

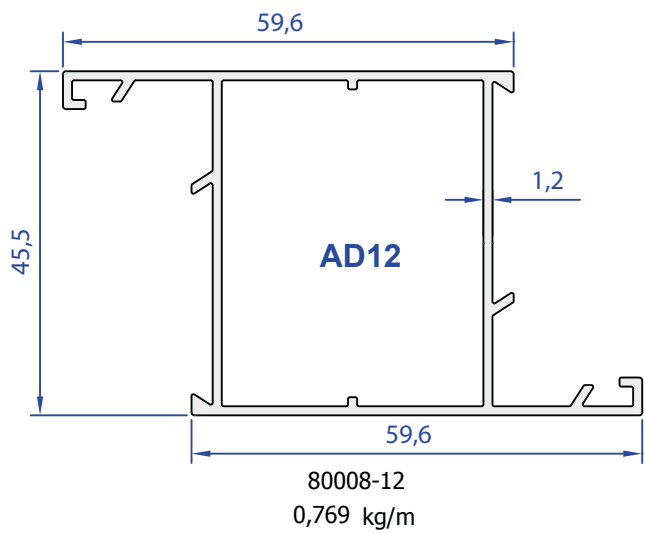
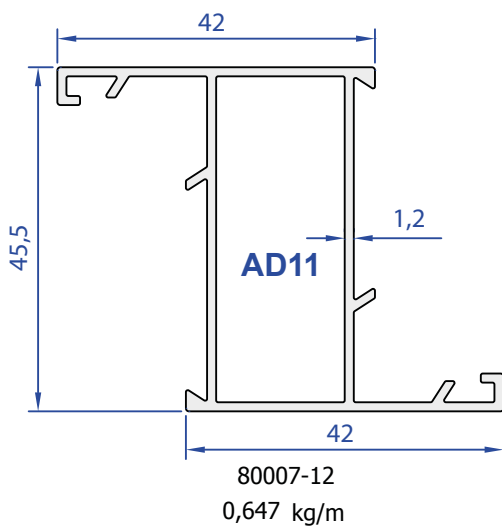
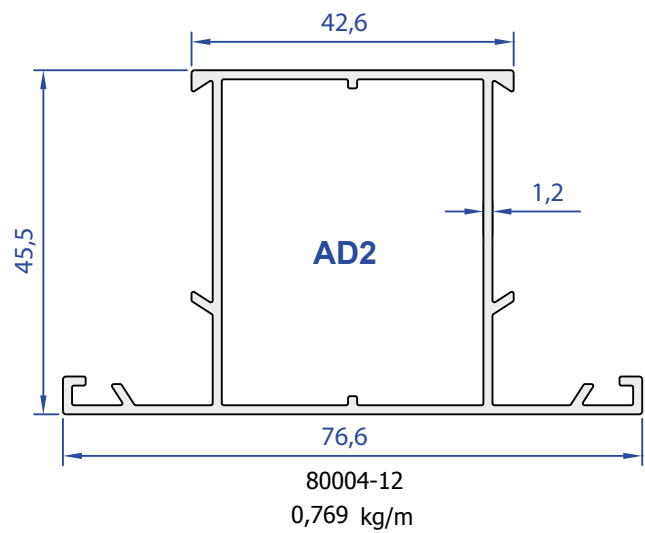
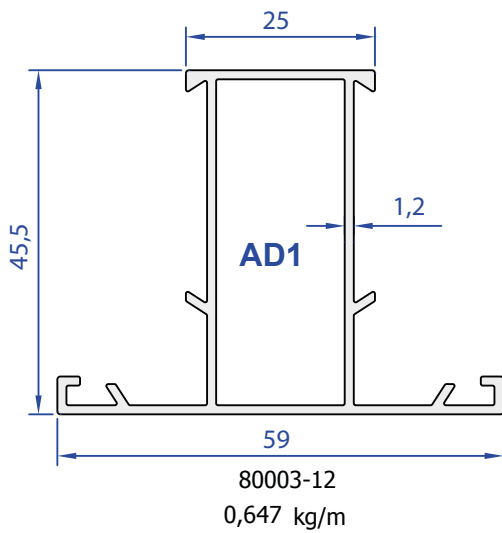
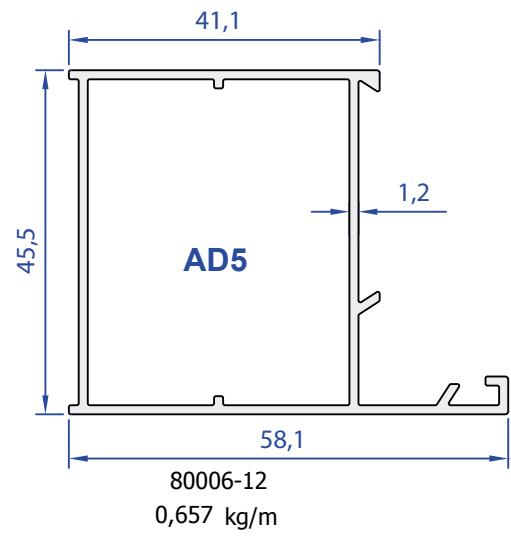
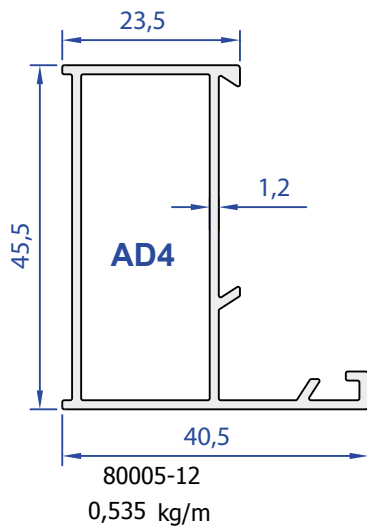

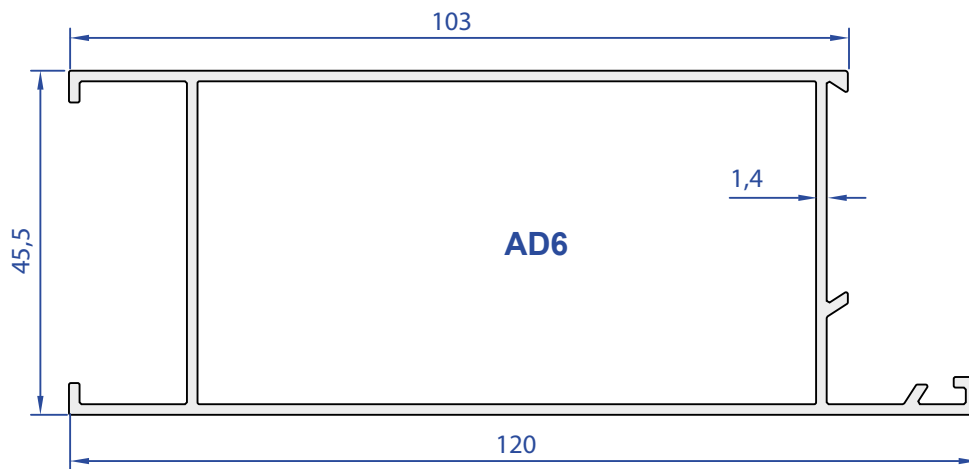

80011-14
1,240 kg/m

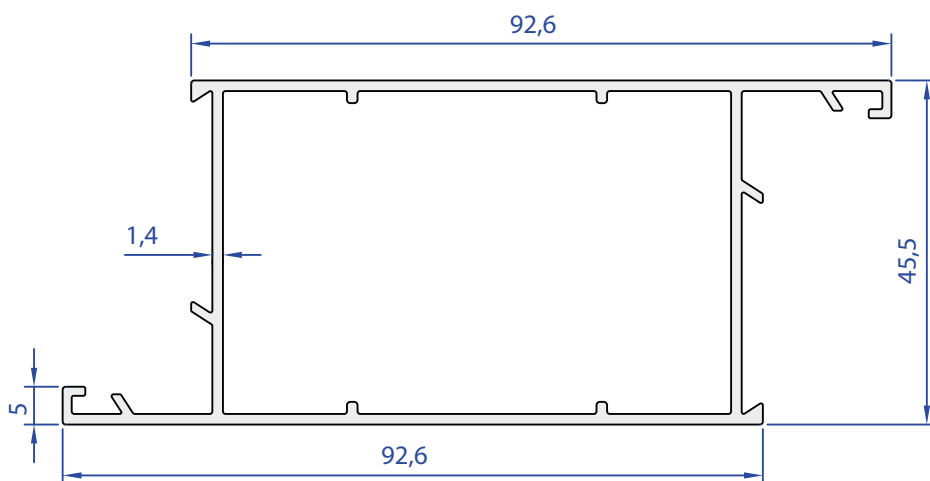

80013-14
1,138 Kg/m

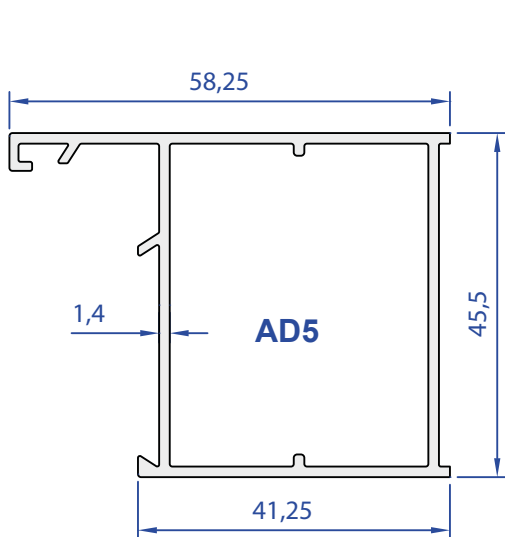

80012-14
0,759 Kg/m

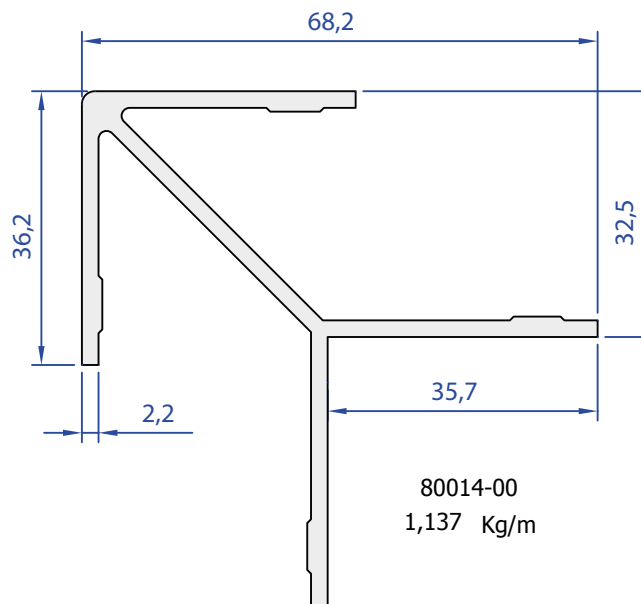

80014-00
1,137 Kg/m

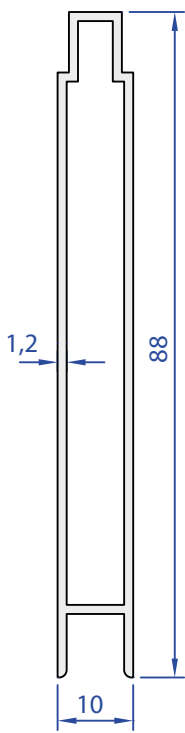

80001-12
0,621 kg/m

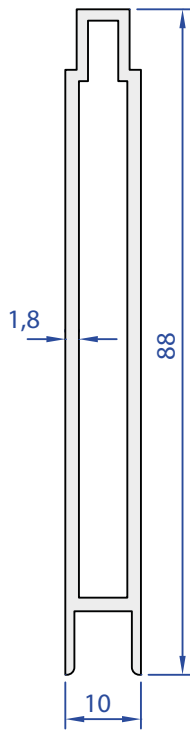

80001-18
0,874 kg/m

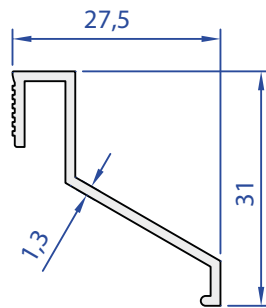

80002-00
0,210 kg/m

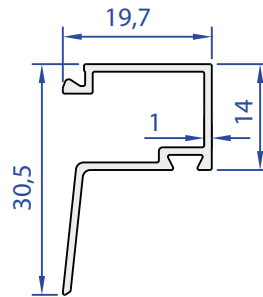

80009-00
0,202 kg/m

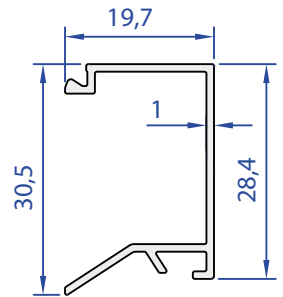

80010-00
0,208 kg/m

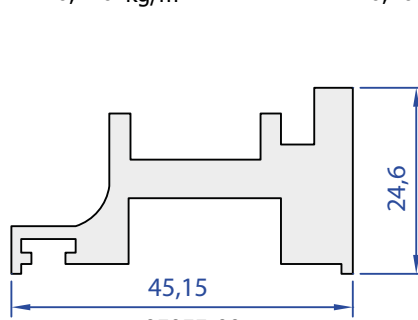

05055-00
1,126 kg/m

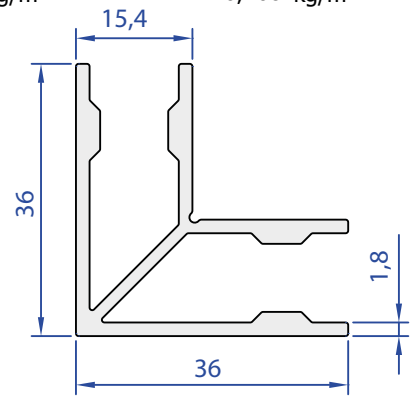

05787-00
0,723 Kg/m

ALDOKS ME NJE XHAM

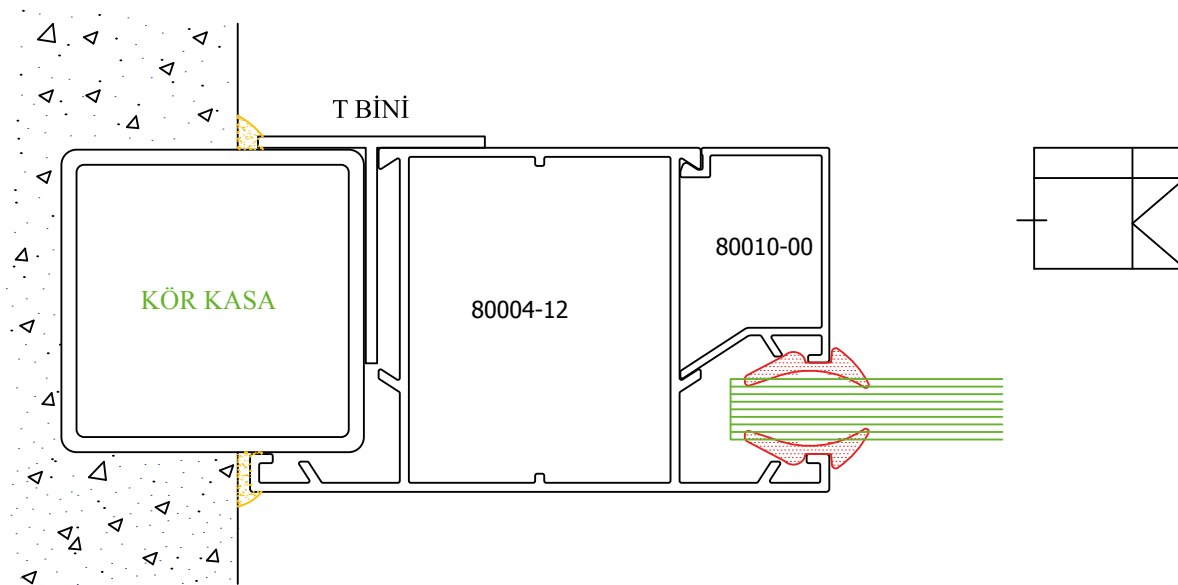
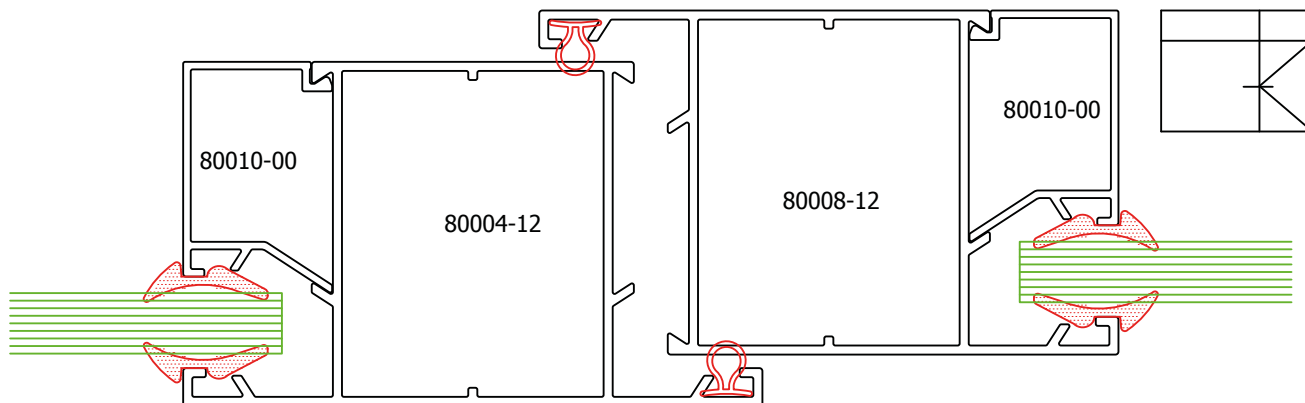
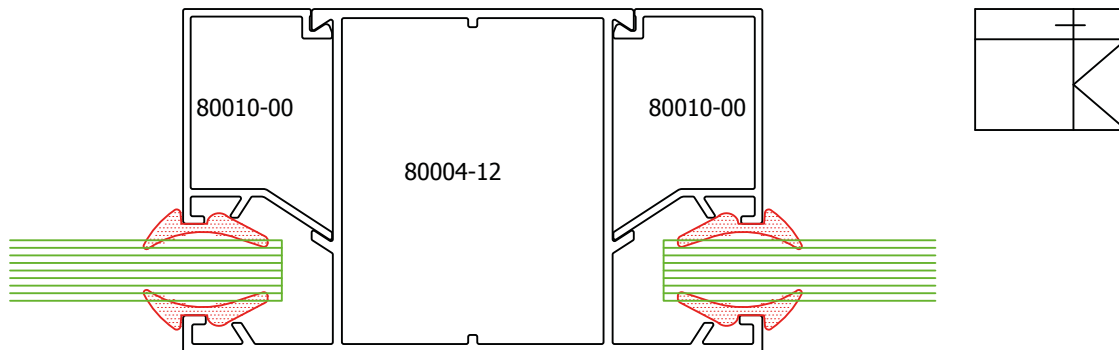

ALDOKS ME NJE XHAM

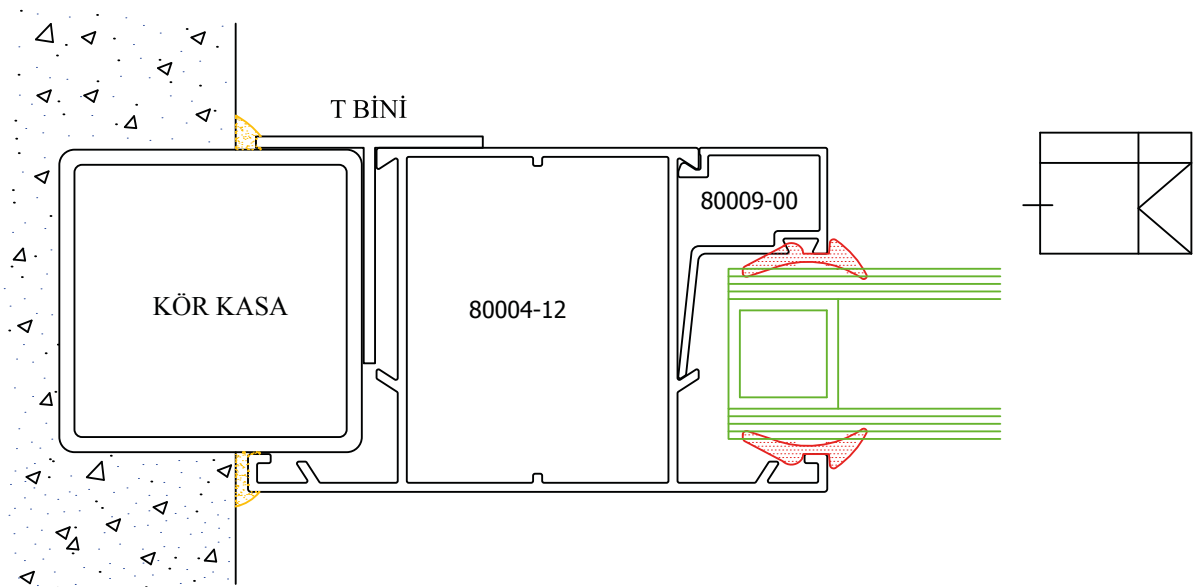
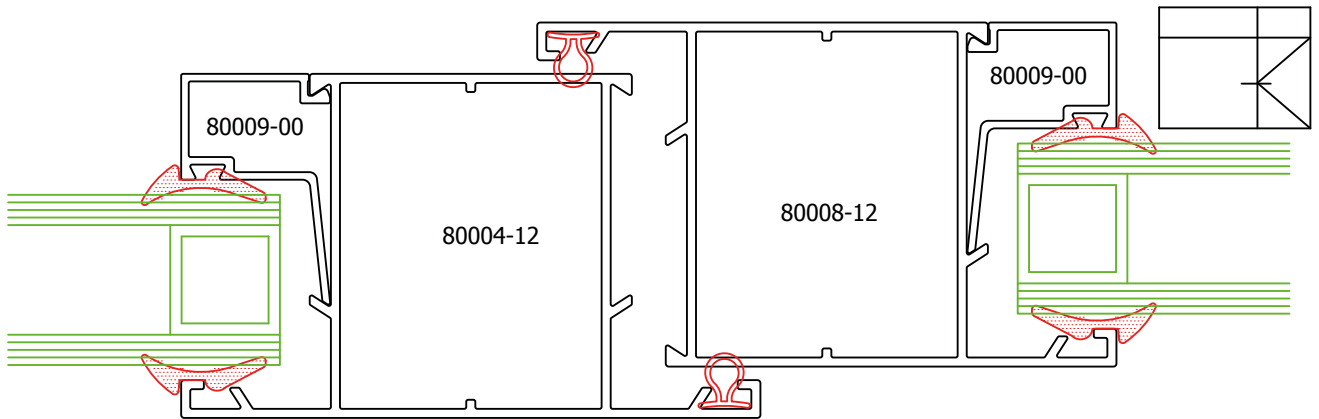
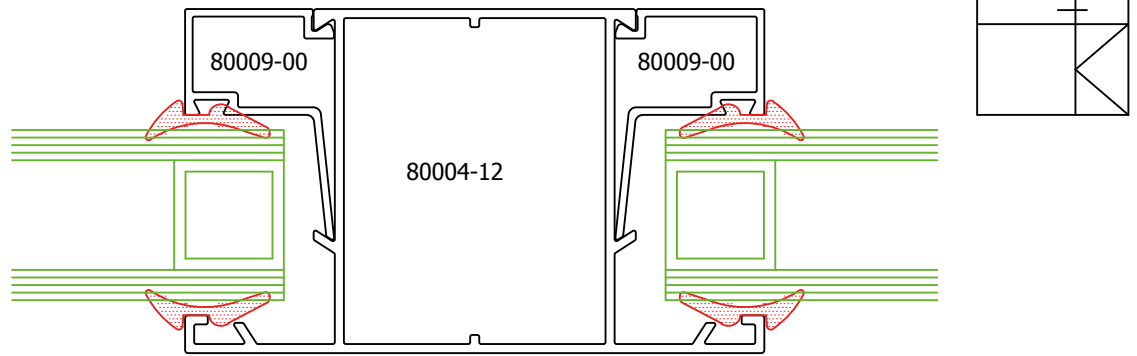

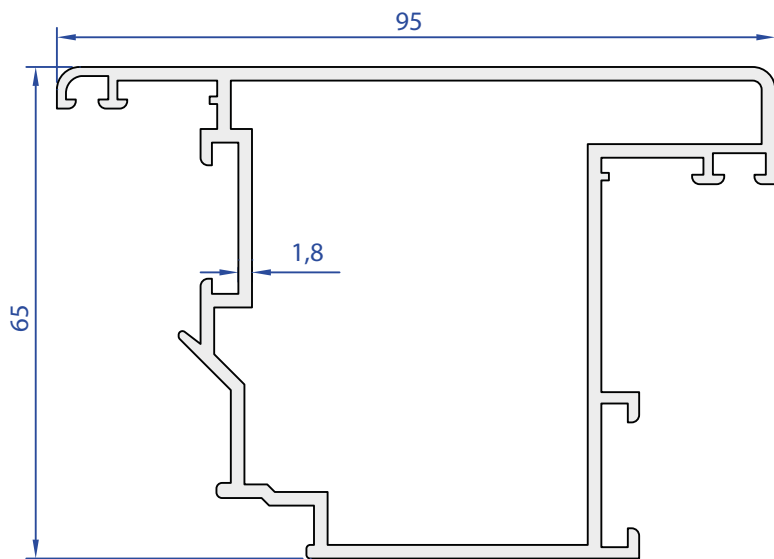

81002-00
1,624 kg/m

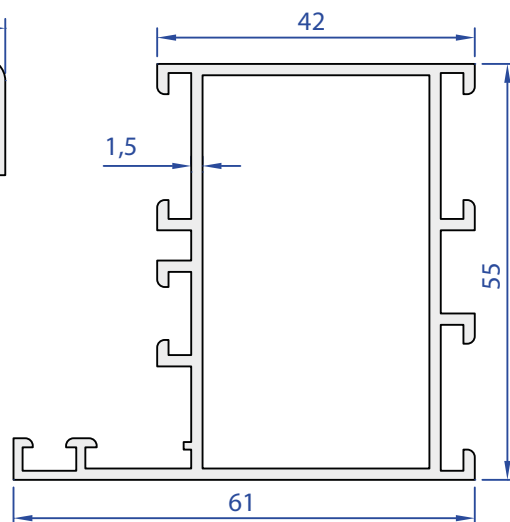

81001-00
1,033 kg/m

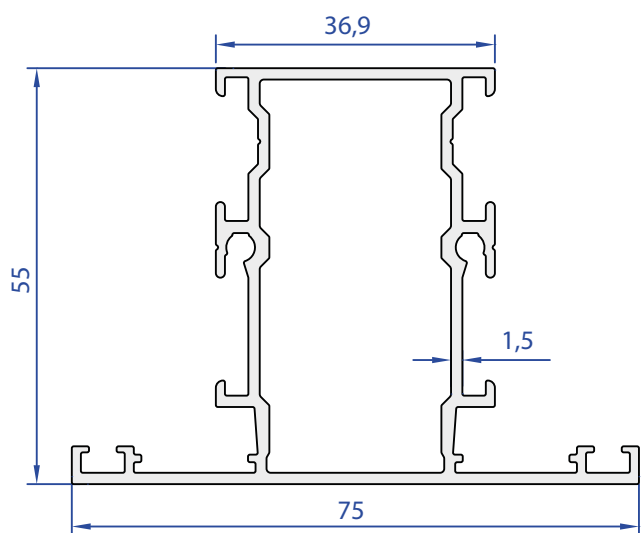

81007-16
1,138 kg/m

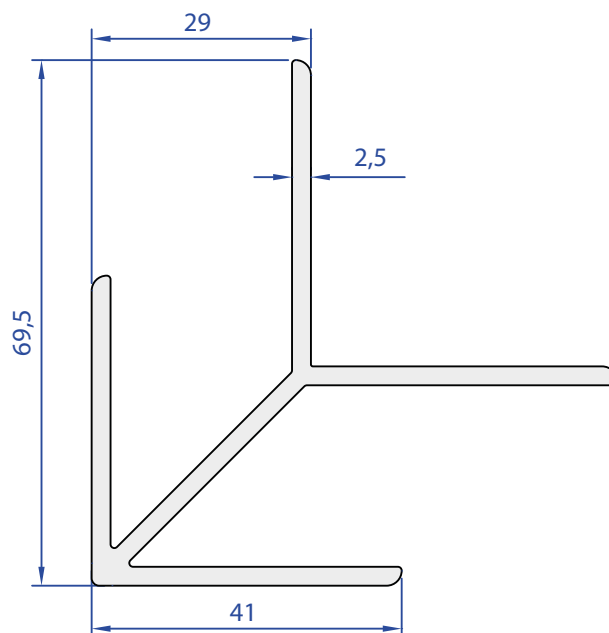

81008-00
1,325 kg/m

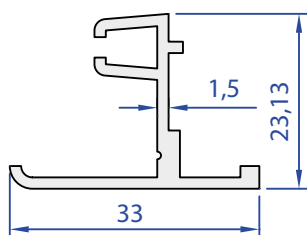

81003-00
0,338 kg/m

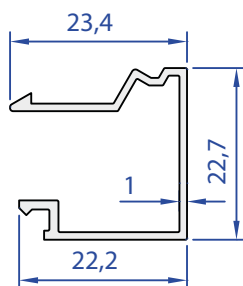

81004-00
0,214 kg/m

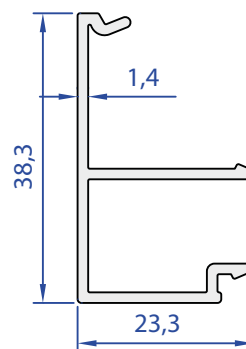

81006-00
0,354 kg/m



81010-00
2,282 Kg/m

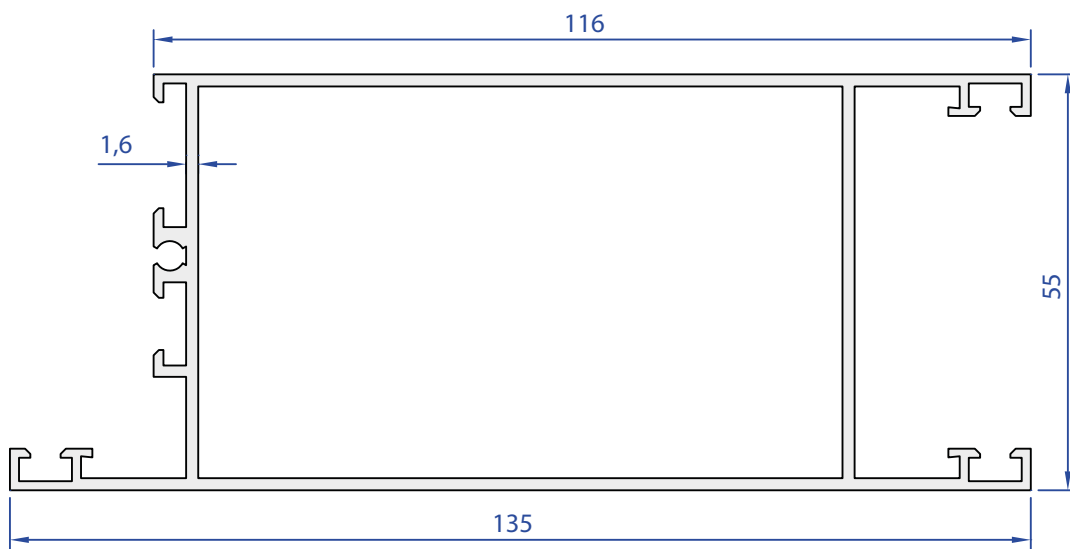

81012-00
1,721 Kg/m

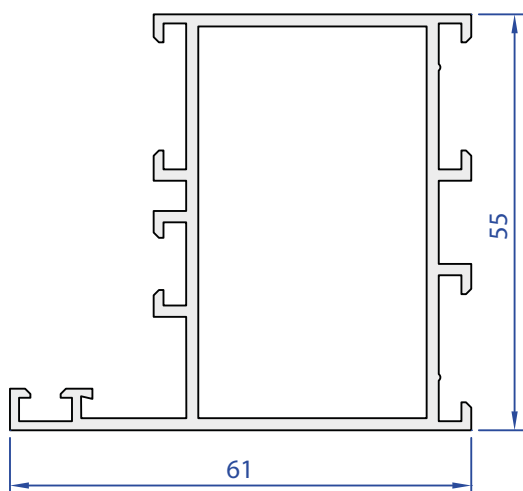

81009-00
1,073 Kg/m

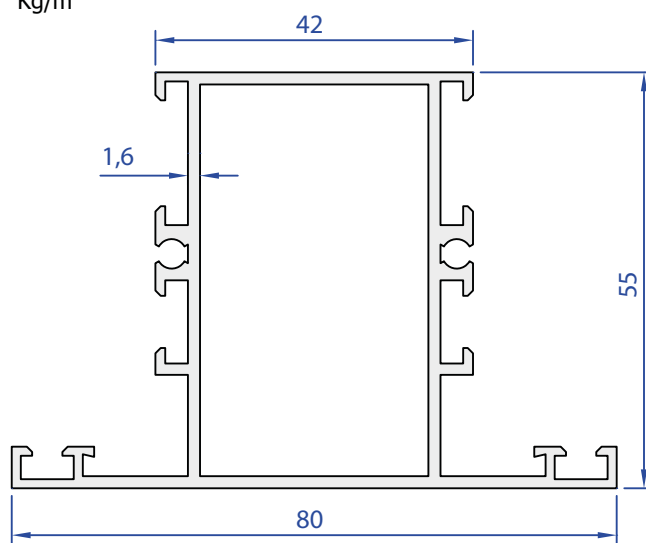

81013-00
1,225 Kg/m

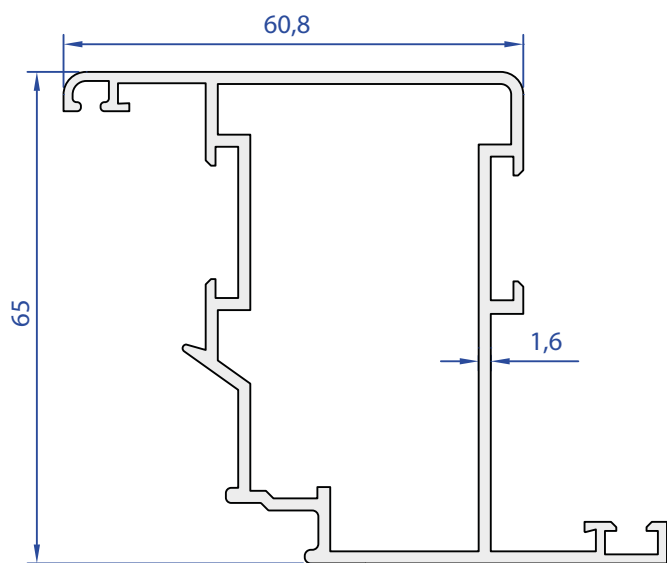

81015-00
1,247 Kg/m

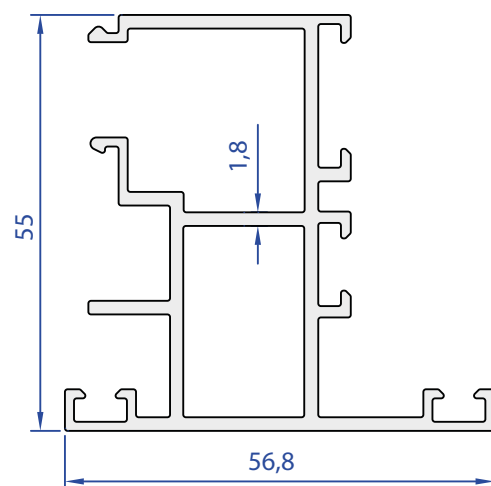

81014-00
1,168 Kg/m

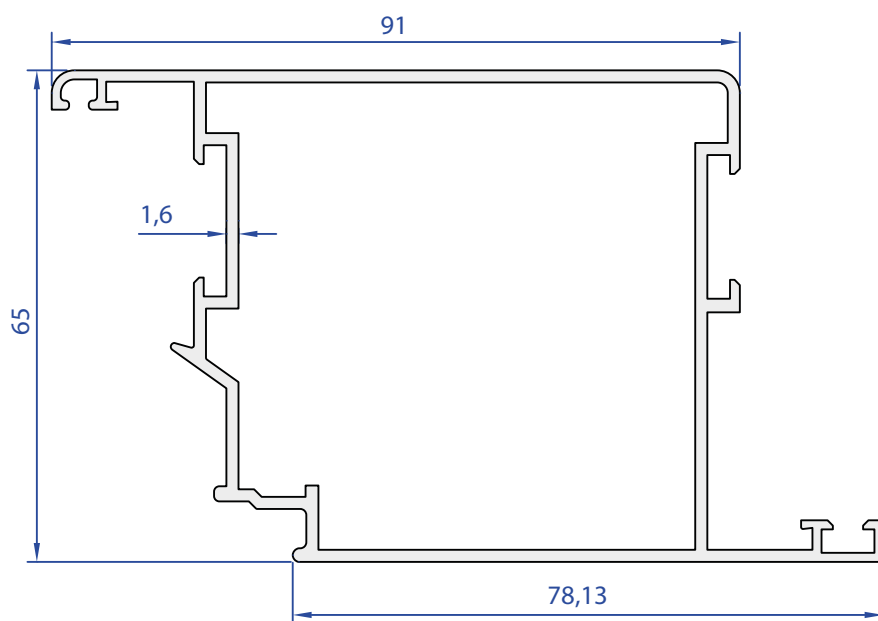

81011-00
1,509 Kg/m

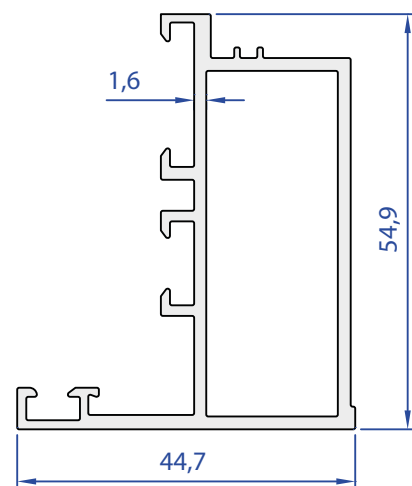

81016-00
0,879 Kg/m

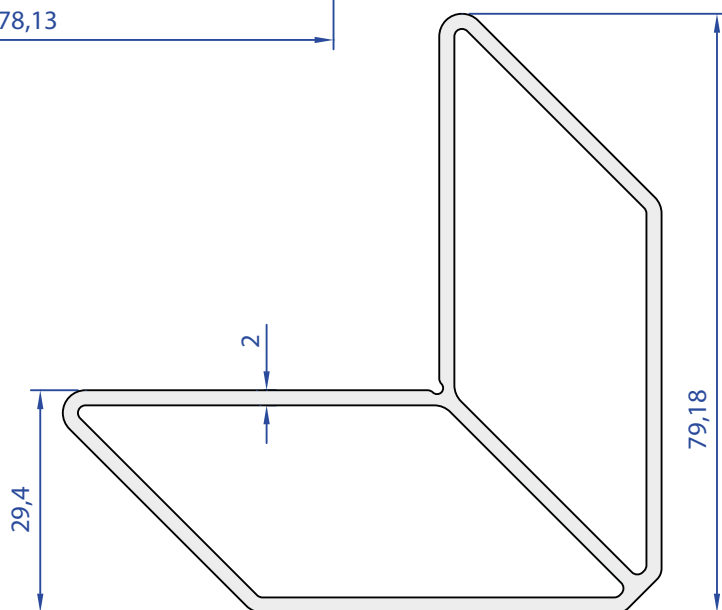

06954-00
1,673 Kg/m

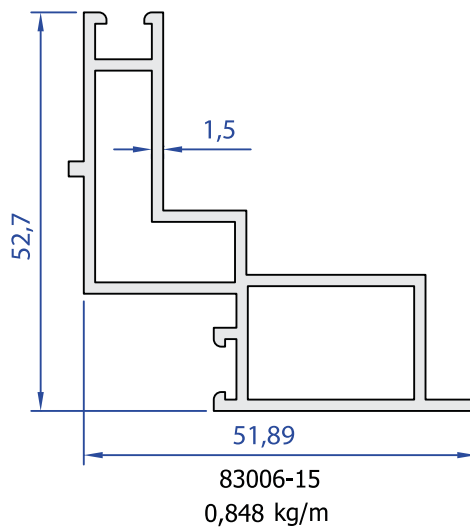
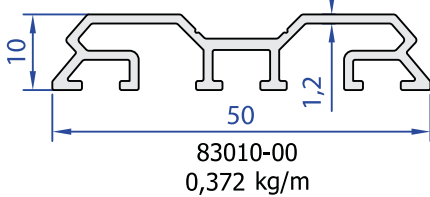
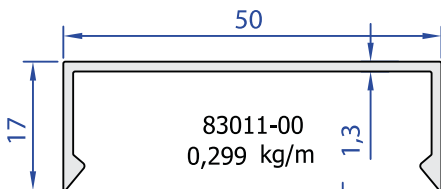
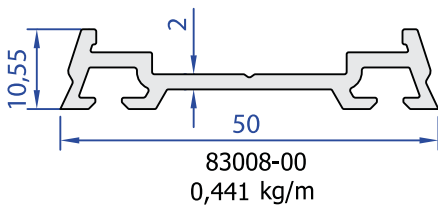
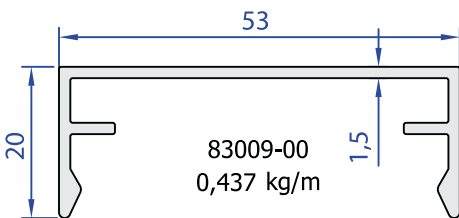
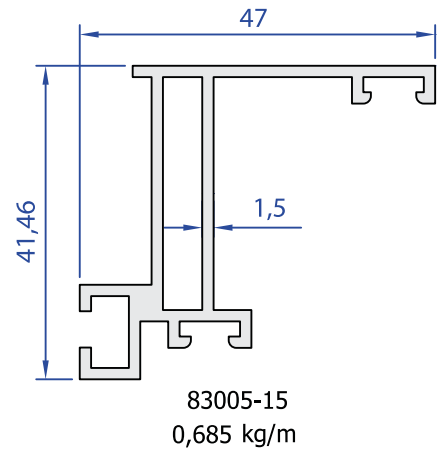
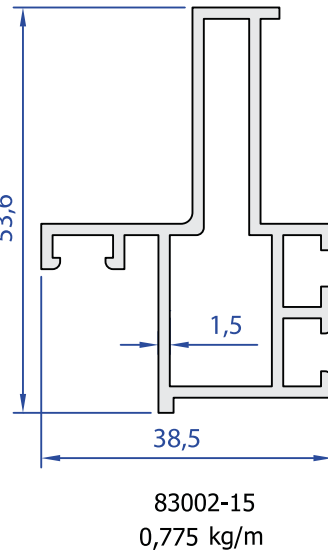
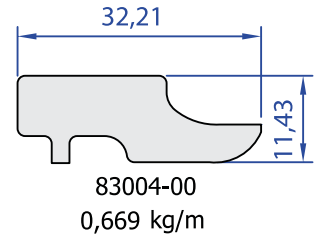
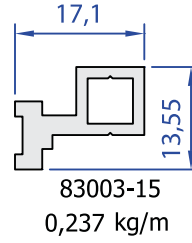
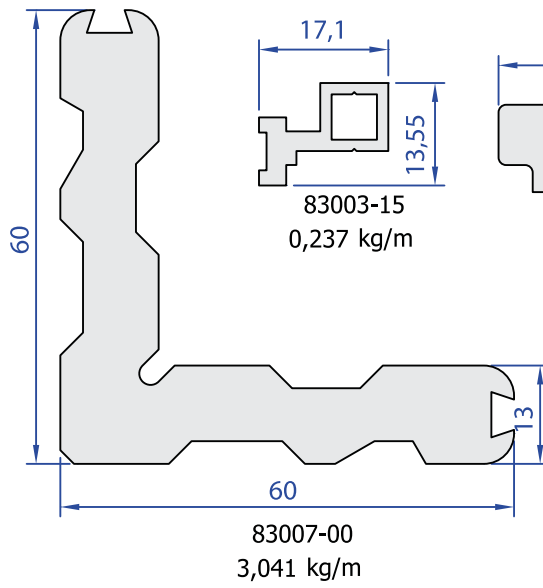
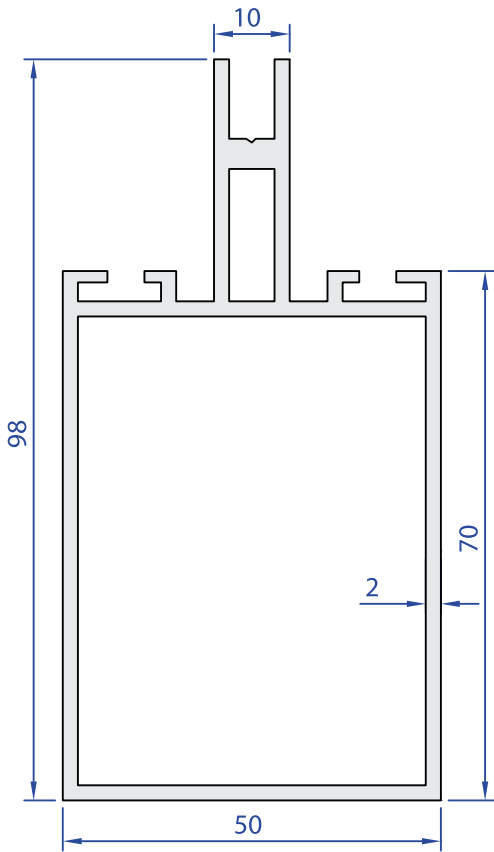

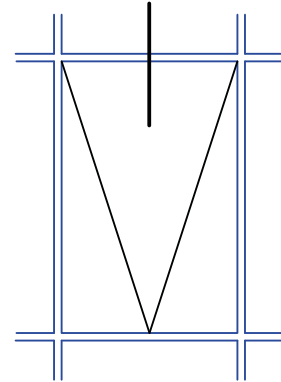
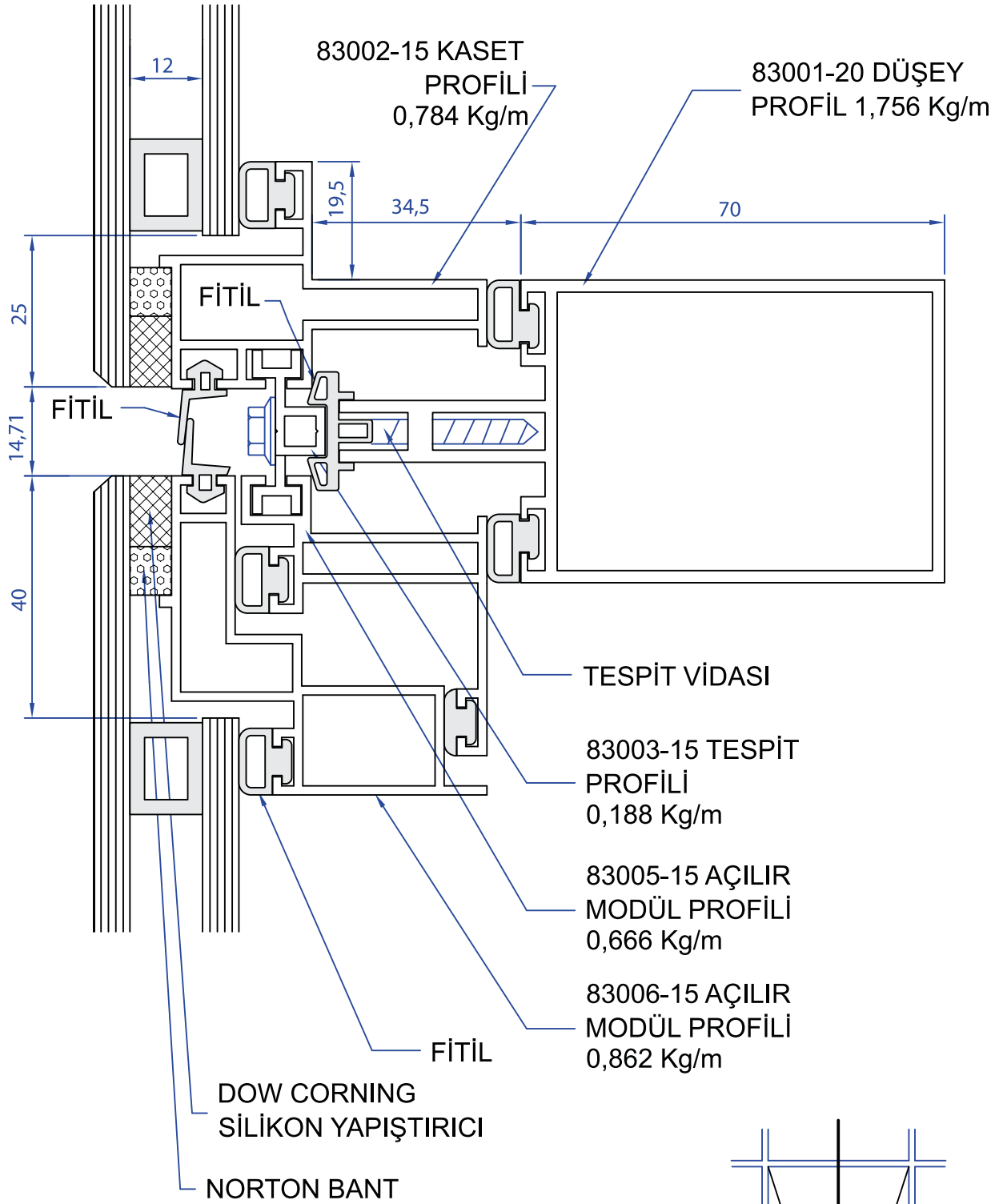

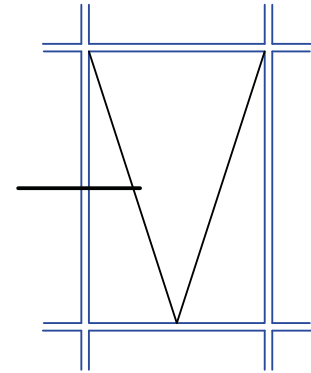
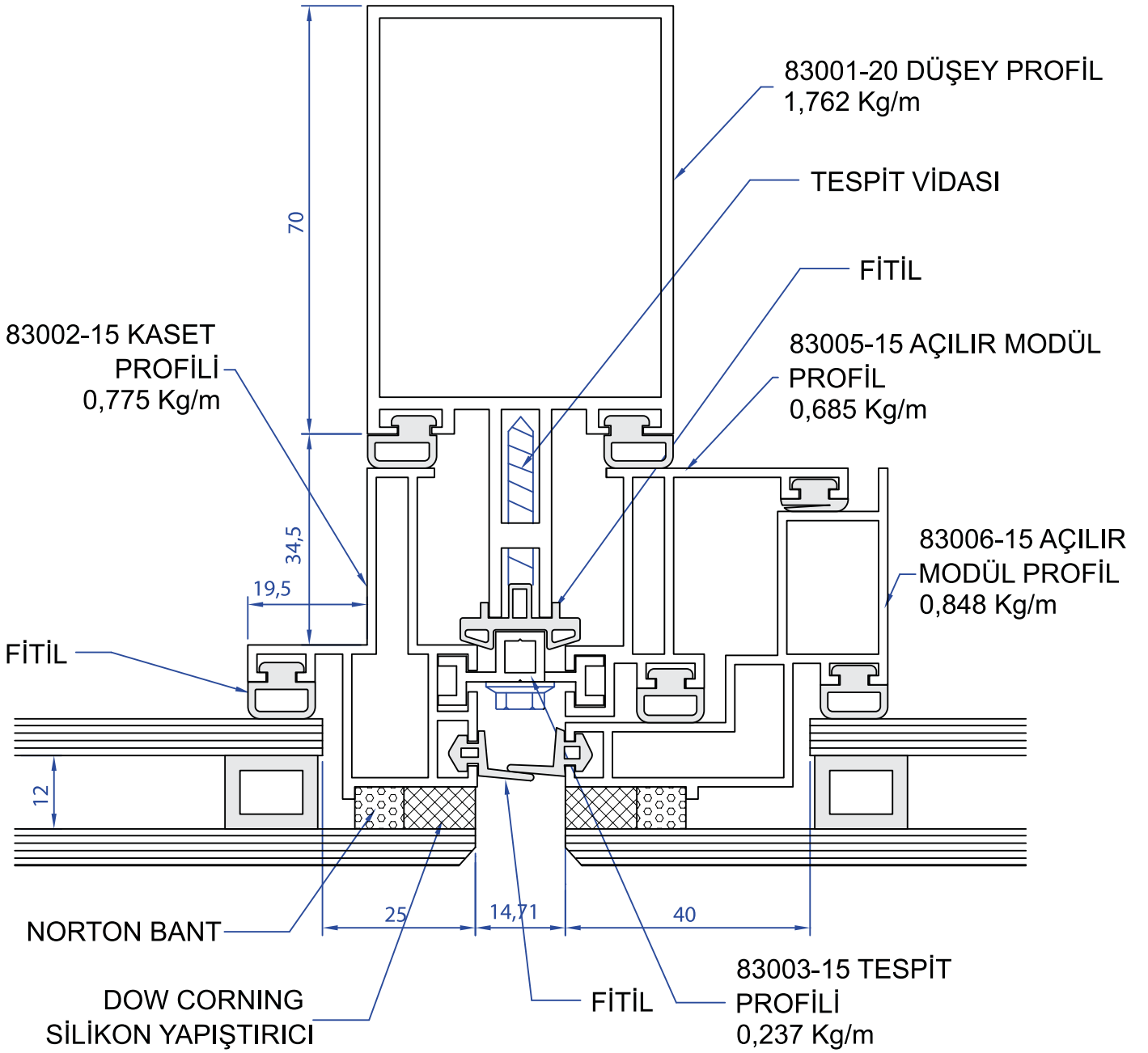

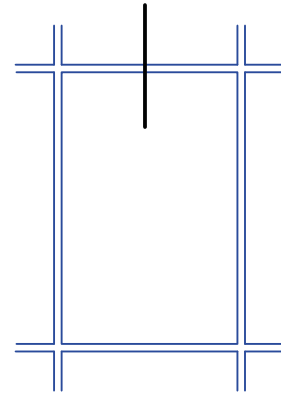
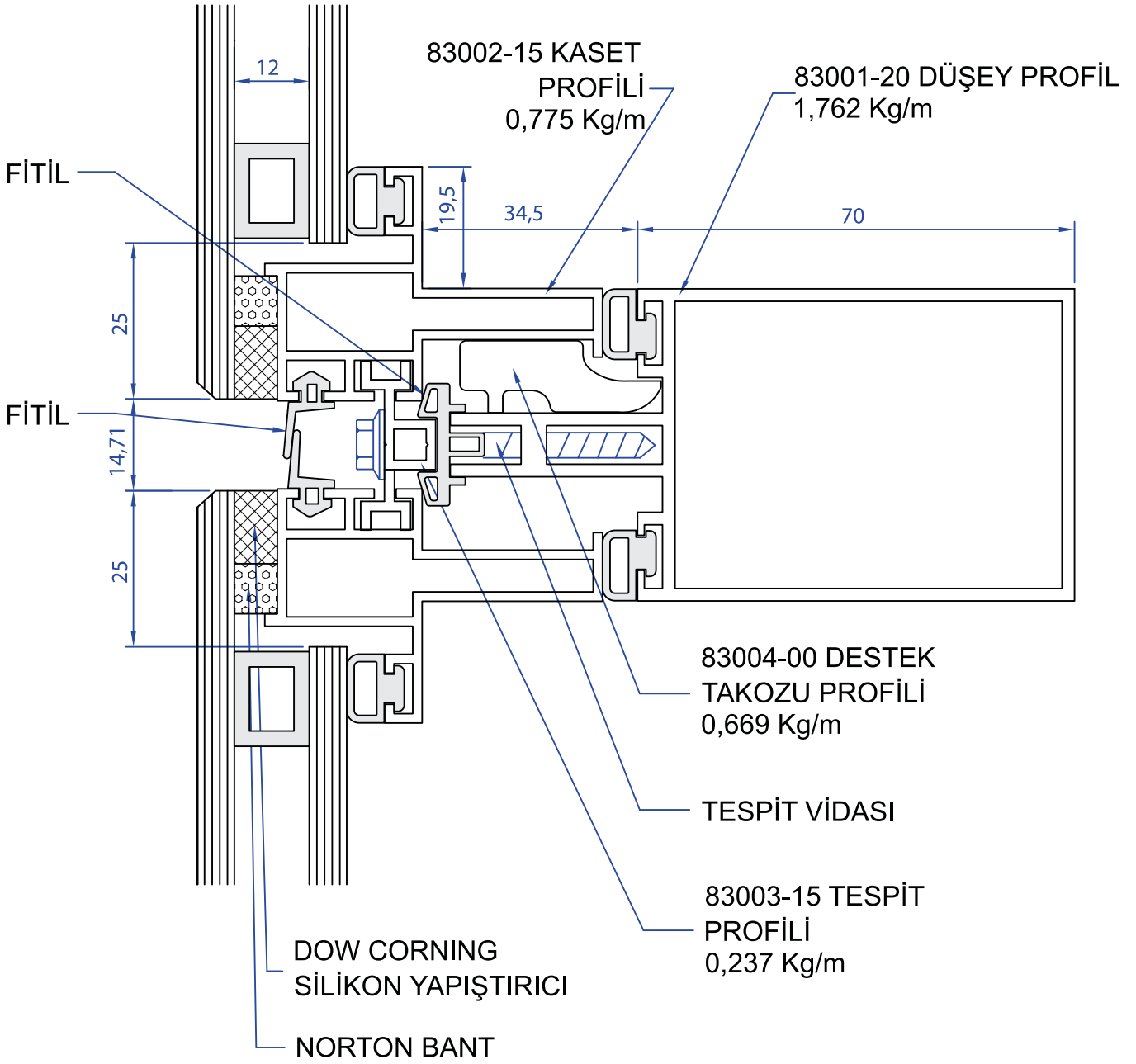

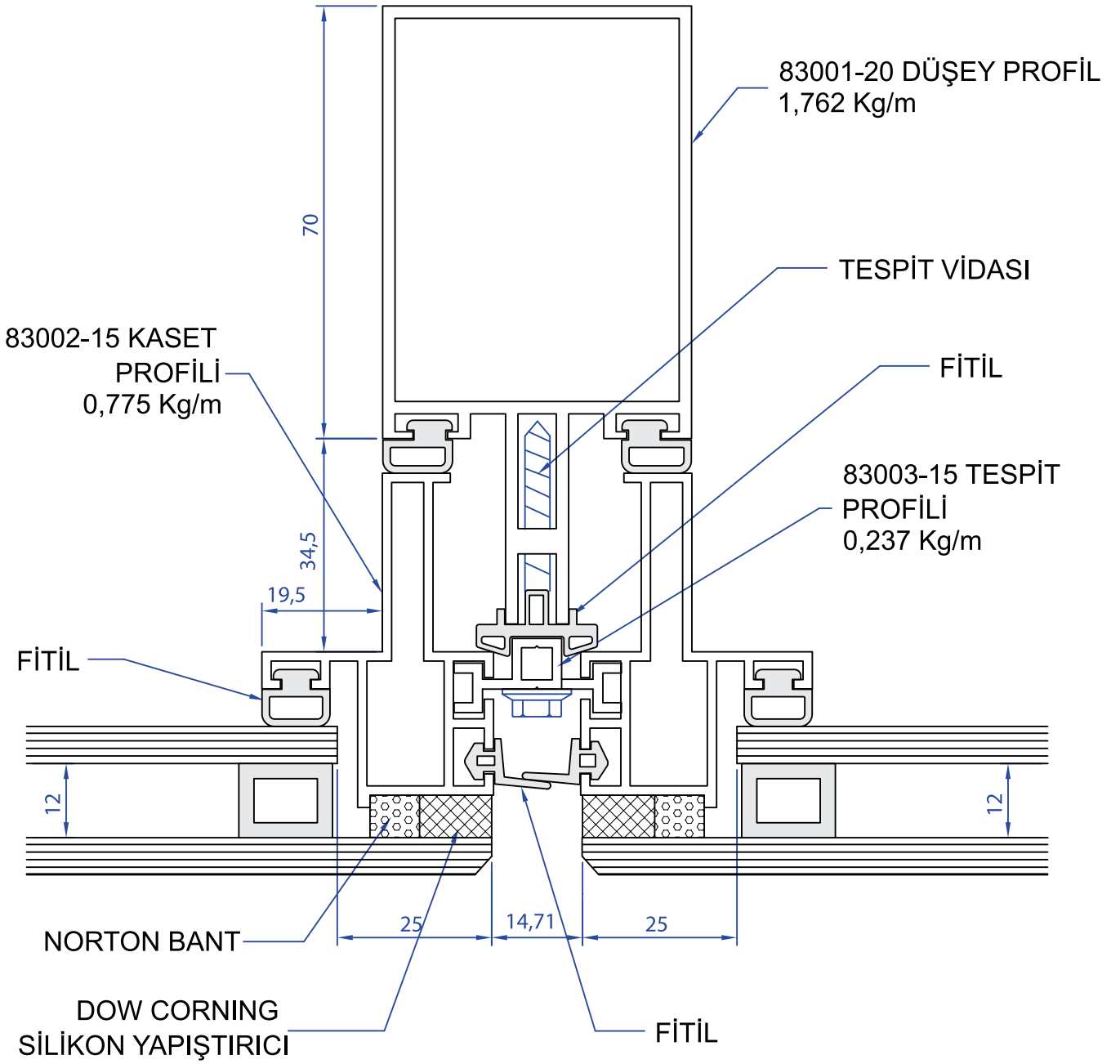

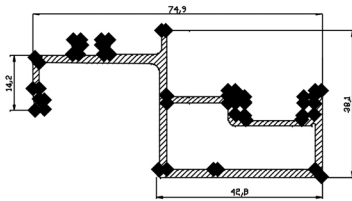

83027-00
1,051 Kg/m

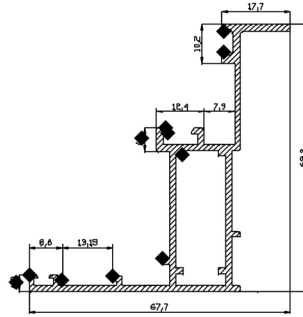

83028-00
0,976 Kg/m

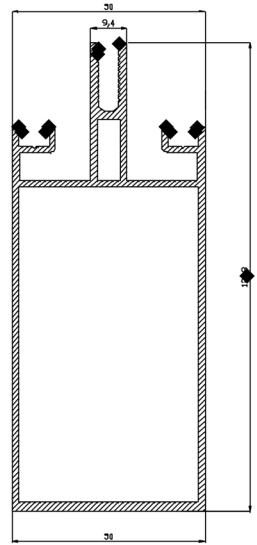

83029-00
2,062 Kg/m

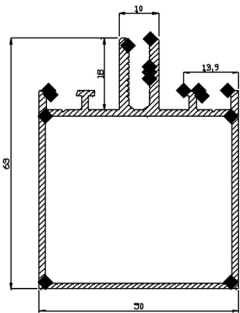

83030-00
1,161 Kg/m

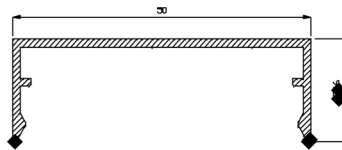

83031-00
0,310 Kg/m

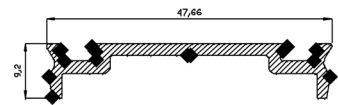

83032-00
0,371 Kg/m

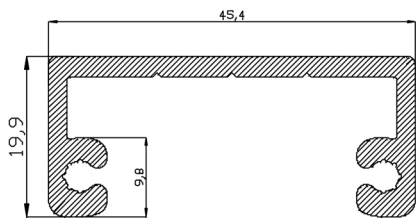

83033-00
0,686 Kg/m

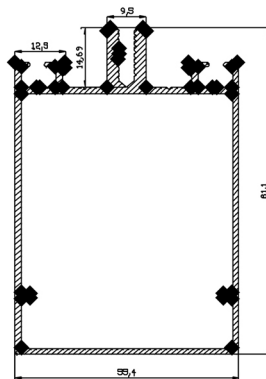

83034-00
1,361 Kg/m

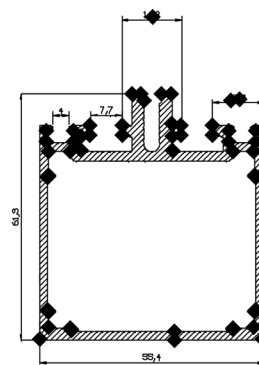

83035-00
1,613 Kg/m

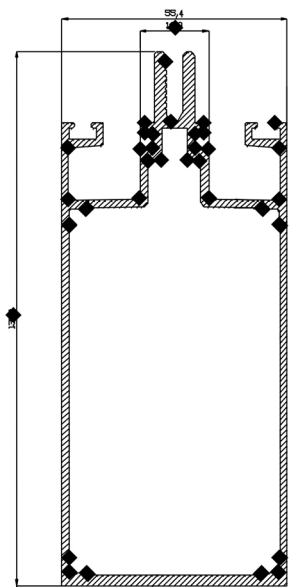

83036-00
2,400 Kg/m

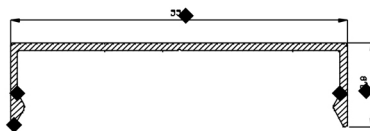

83037-00
0,281 Kg/m

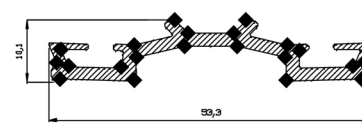

83038-00
0,447 Kg/m

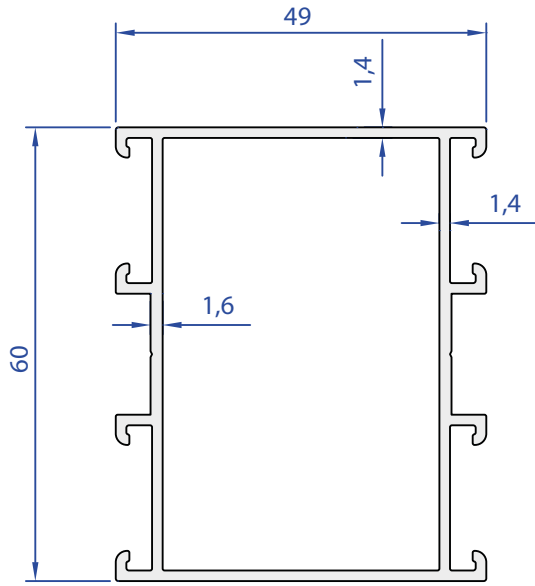

85001-00
0,976 Kg/m

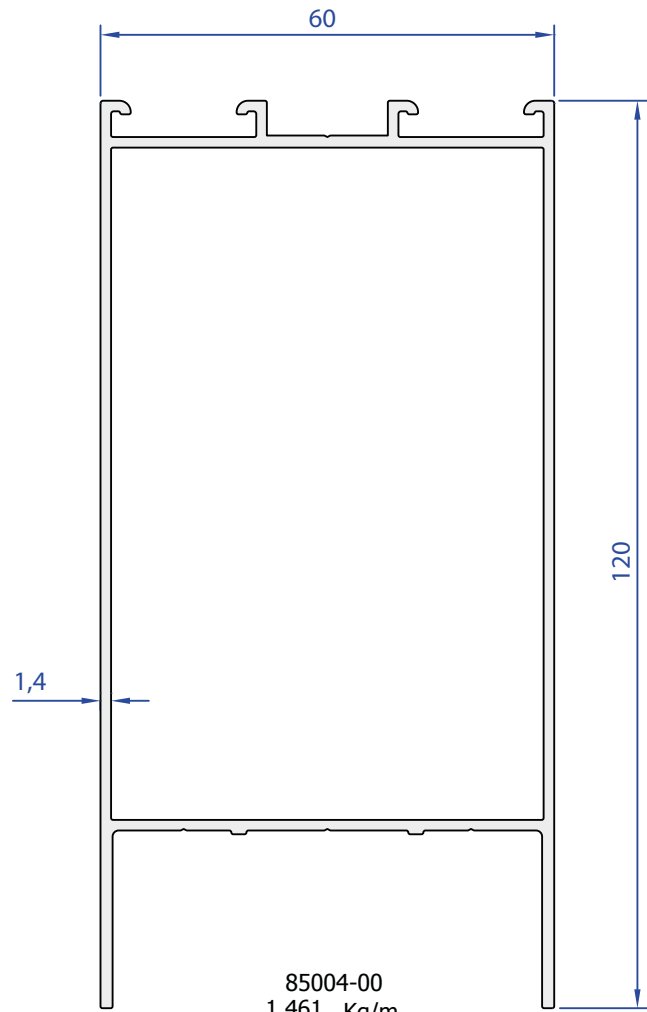

85004-00
1,461 Kg/m

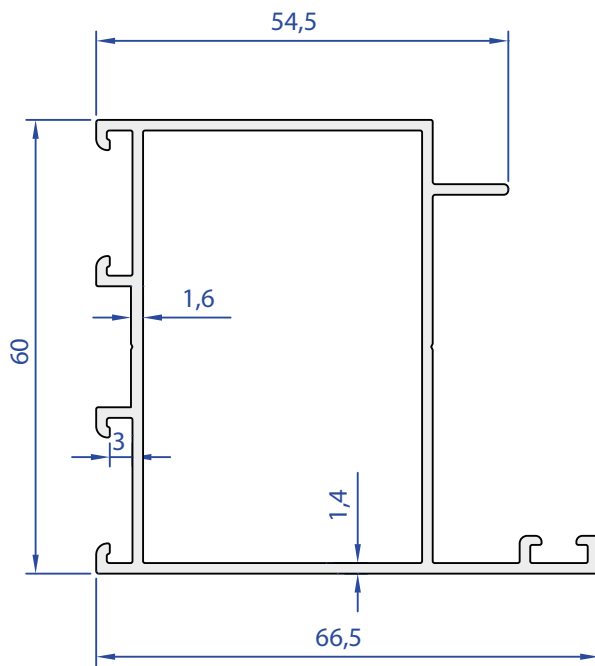

85002-00
1,015 Kg/m

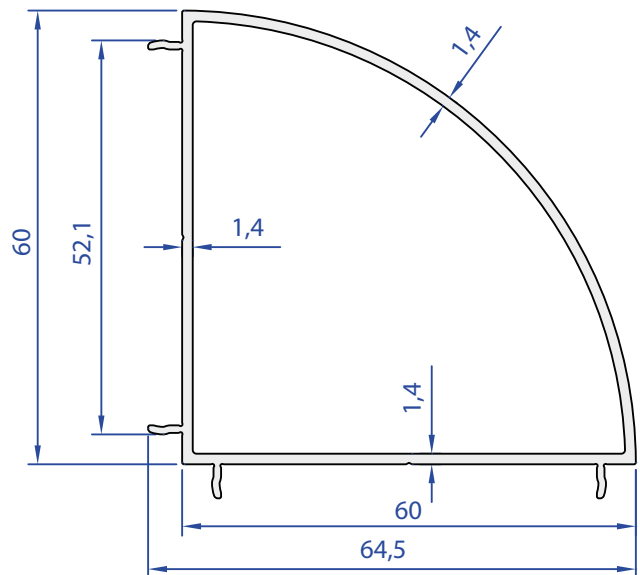

85007-00
0,840 Kg/m

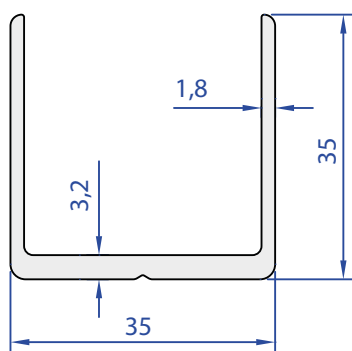

85006-00
0,607 Kg/m

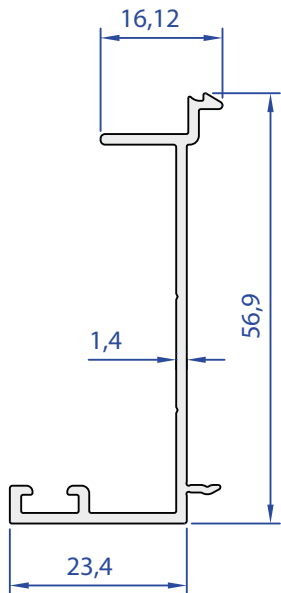

85008-00
0,399 Kg/m

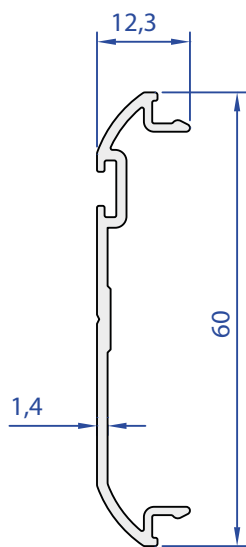

85009-00
0,333 Kg/m

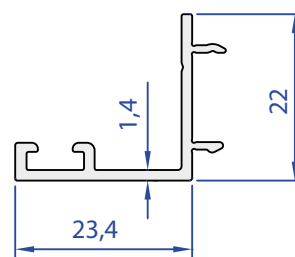

85010-00
0,226 Kg/m

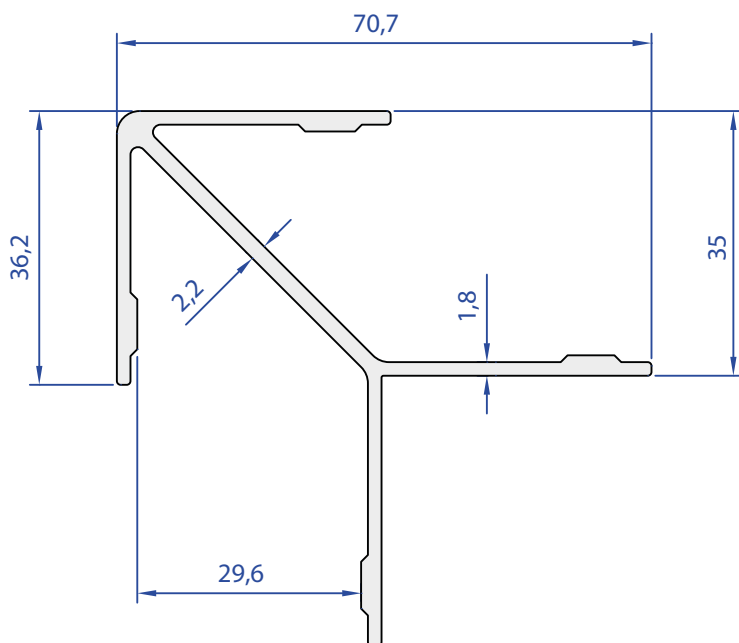

85005-00
1,039 Kg/m

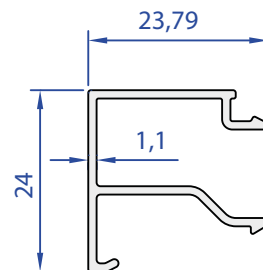

85003-00
0,238 Kg/m

ALUFINN 